

The NBM dust collector is designed to filter volumes of air varying from 1000 CFM to 12000 CFM.

This dust collector uses BELFAB's patented modular technology, allowing to add-on filtration modules when the volume of air to be filtered increases, or to optimize the filtration ratio cost-effectively.

The NBM can operate with BELFAB'S upgradeable fans, a patented technology. These fans can be modified to increase the airflow from 2 HP / 1000 CFM up to twin 20 HP / 12 000 CFM fans. This is accomplished by replacing the inlet, fan wheel and motor of the fan.

Different dust disposal options are available, varying from the simple steel drum, the easy to handle plastic tilt truck to the high production pneumatic dust transfer system.



Dust Disposal Options

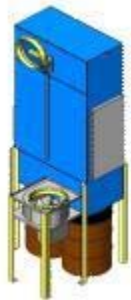

*Steel drums or plastic bags
(Standard, drums not included)*



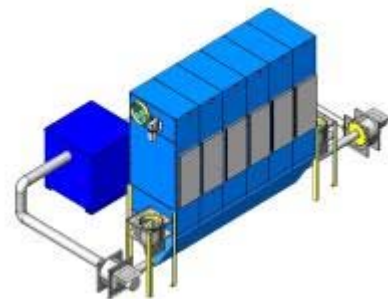

*Plastic tilt trucks
(Plastic tilt truck option)*

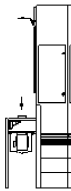
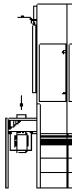
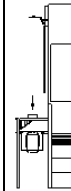
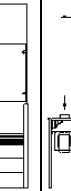

*Pneumatic dust transfer system
(Pneumatic dust transfer system option)*

SPECIFICATIONS (single fan configuration)

MODULE ARRANGEMENT						
NB OF FILTER MODULES	1	2	3	4	5	6
FILTER SURFACE (sq.ft.)	165	330	495	660	825	990
DIMENSIONS (in.)* (D) X (W) X (H)	48x48x144	72x48x144	96x48x144	120x48x144	144x48x144	168x48x144
MODULES WEIGHT (lbs)	690	1 040	1 390	1 740	2 090	2 444

*When equipped with Hummer blower, add 18" to width.

	STANDARD BLOWER 3600 RPM					HUMMER BLOWER 1800 RPM				
FAN MODULE (HP)	5HP	7.5HP	10HP	15HP	20HP	10HP	15HP	20HP	25HP	30HP
CAPACITY (PCM)	2 500	3 500	4 600	5 000	6 000	4 600	5 000	6 000	7 500	9 000
RECOMMENDED NUMBER OF FILTER MODULES	1 to 3	2 to 4	2 to 5	3 to 6	4 to 6	2 to 5	3 to 6	4 to 6	5 to 7	7 - 8
SOUND PRESSURE LEVEL (dB) @ 10'	82	84	88	92	92	78	81	83	85	87
INLET DIAMETER (in.)	9	10	12	14	16	12	14	16	18	20
MODULE WEIGHT (lbs)	200	240	250	340	360	350	450	560	620	680

FEATURES

- Direct drive centrifugal fan.
- High efficiency TEFC motor, UL & CSA approved.
- AMCA Class B (standard) & Class C (Hummer) anti spark blower assembly.
- High efficiency polytwill filter bag 98.98% @ 0.5 micron.
- Comes standard with manual shaker
- Drum attachments: filter sleeve & quick release clamp
- The NBM collector can operate in either push or pull conf.
- Integrate explosion doors that meet NFPA 68.
- Each filter module comes with a maintenance access door.

OPTIONS

- 55 gallon steel drum.
- Plastic tilt truck & adaptor.
- Hopper modules & transfer blower.
- Control panel with automatic shaker.
- Explosion vent conduit, two-way valve, tee derivation, abort damper, spark detection system.
- Pre-wired starter.

GUARANTY

All BELFAB manufactured equipment carry a one-year guaranty.

* BELFAB improves its products continuously and may change the specifications without notice.

DISTRIBUTED BY:



PERFORMANCE CURVES

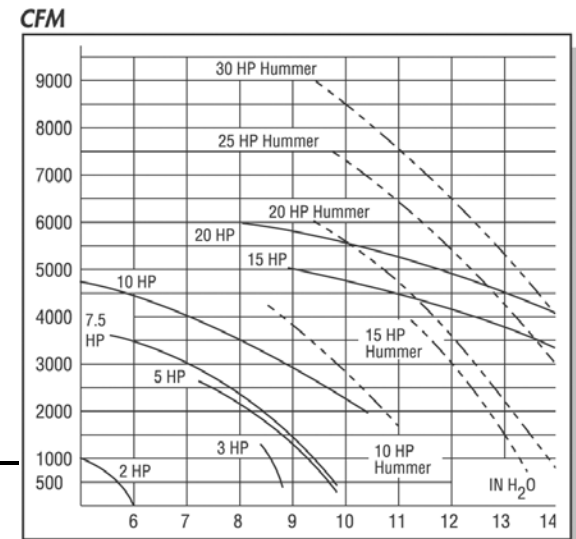

Note: if your installation develops less static pressure than the minimum indicated on this chart, slide gate restriction should be added in order not to exceed recommended maximum motor amperage.

Belfab

430 Guimond, Longueuil, QC, CANADA J4G 1P8

Tel: (450) 463-3344 Fax: (450) 463-3252

Toll free: 1-866-4BELFAB

1-866-423-5322

Website: www.belfab.net

E-mail: sales@belfab.net